

NDIR Gas Analyzer

Single or Dual Channel Version

BA 6000 - IR



The BA6000 IR single or dual channel gas analyzer operates as a NDIR instrument. It is ideally suited to measure any gas in the IR region between 2 and 9 μm , such as CO, CO₂, NO, SO₂, NH₃, H₂O, CH₄ and other hydrocarbons.

Single channel analyzers measure one gas component while dual channel analyzers measure two gas components simultaneously and independently of one another.

The standard configuration of this analyzer is designed for use in non-explosive atmospheres.

- **Four programmable measurement ranges per channel**
- **Electrically isolated signal outputs 0/2/4 to 20 mA per channel**
- **Auto-ranging or manual range selection**
- **Differential measuring ranges with flowing reference cell**
- **Storage of measured values during calibration**
- **Selectable time constants**
- **Menu based operation**
- **Fast response time**
- **Low long-term drift**
- **Two-stage access code**
- **Pressure correction**
- **Optional external pressure sensor**
- **Automatic range calibration**
- **Monitoring of sample gas (flow and pressure)**
- **One RS 485 serial interface per channel**

Design Characteristics

Housing

- 19" unit with 4 HU for installation in hinged bays
- 19" unit with 4 HU for installation in cabinets, with or without telescopic rails
- Front panel can be swung down for servicing (laptop connection)
- Internal pressure sensor for correction of pressure variations in sample gas
- Internal gas paths: FPM (Viton) hose or titanium piping
- Measuring chamber (with or without flow-type compensation branch) made of stainless steel or tantalum for highly corrosive sample gases (such as HCl, Cl₂, SO₂, SO₃, etc.)
- Gas connections for sample gas inlet and outlet and for reference gas: piping diameter 6 mm or 1/4"

Display and control panel

- Large LCD panel for simultaneous display of:
 - measured value (digital and analog displays)
 - status line
 - measurement rangesContrast of LCD panel adjustable by menu
- Permanent LED backlighting
- Easy-to-clean membrane keyboard with five softkeys
- Menu-based operation for setting, test functions, calibration
- User help in plain text
- Graphic display of concentration trend; adjustable time intervals

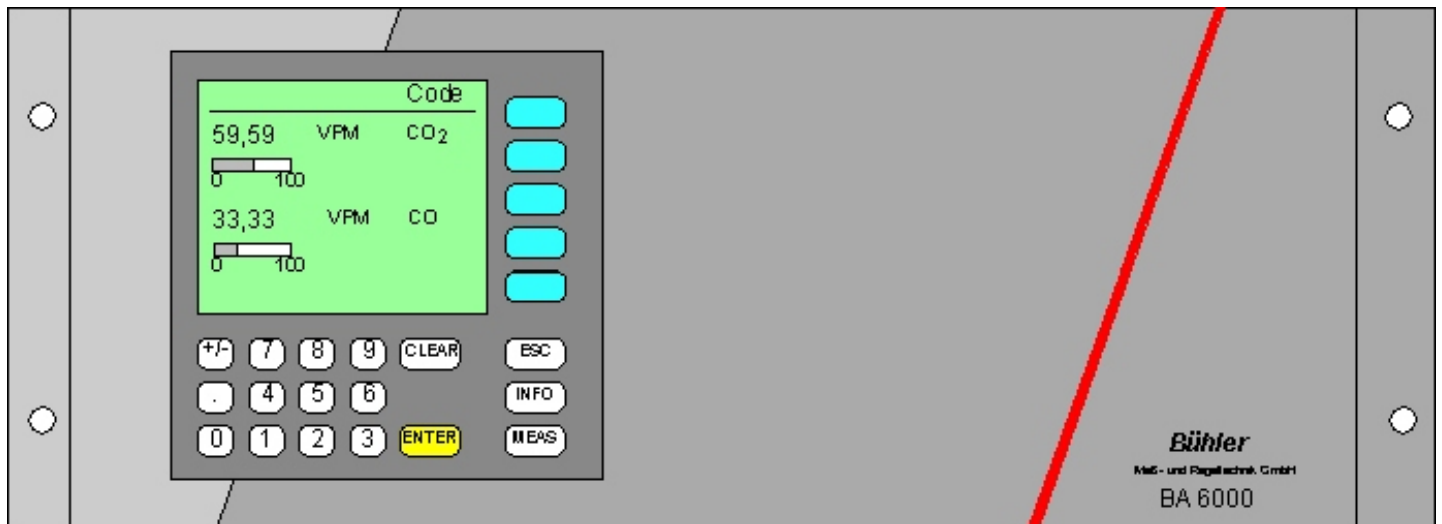

Inputs / outputs

- Six binary inputs freely configurable (e.g. range switching)
- Six relay outputs freely configurable (e.g. failure, maintenance request, maintenance switch, limit alarm, external solenoid valves)
- Two configurable analog inputs (e.g. correction of cross-interferences)
- Optional extension, with 8 additional binary inputs and eight additional relay outputs for automatic calibration with up to four calibration gases

Interfaces

- Serial RS 485

Mode of operation

The BA 6000 - IR gas analyzer operates according to the infrared two-beam alternating light principle with double-layer detector and optical coupler.

The measuring principle is based on the molecule-specific absorption of infrared radiation. The absorbed wavelengths are characteristic to the individual gases, but may partially overlap. This results in cross-sensitivities which are reduced to a minimum in the BA 6000 - IR gas analyzers by the following measures:

- Filter cell filled with gas (beam splitter)
- Double-layer detector with optical coupler
- Optical filters depending on application

An IR source (4), which is heated to approx. 1300 °F and can be shifted to balance the system, is divided by the beam splitter (6) into two equal beams (sample and reference beam) The beam splitter acts also as a filter cell.

The reference beam passes through a reference cell (10) filled with N₂ (a non-infrared-active gas) and reaches the right-hand side of the detector (11) practically unattenuated. The sample beam passes through the sample cell (9) containing the sample gas flow and reaches the left-hand side of the detector (13) attenuated by an extent depending on the concentration of the sample gas. The detector is filled with a defined concentration of the gas component to be measured.

The detector is designed as a double-layer detector. The center of the absorption band is preferably absorbed in the upper detector layer, the edges of the band are absorbed to approx. the same extent in the upper and lower layers. The upper and lower detector layers are connected via the microflow sensor (3). This coupling reduces the spectral sensitivity to a very narrow band.

The optical coupler (12) lengthens the lower detector chamber layer optically. The infrared absorption in the second detector layer is varied by changing the position of the slider (14). It is thus possible to individually minimize the influence of interfering components.

A chopper (7) rotates between the beam splitter and the sample cell and interrupts the two beams alternately and periodically. If absorption takes place in the sample cell, a pulsating current is generated which is converted by the microflow sensor (3) into an electric signal.

The microflow sensor consists of two nickel grids heated to approx. 250 °F which, are part of a Wheatstone-bridge.

The pulsating flow together with the very close arrangement of the Ni-grids leads to a change in resistance. This leads to an offset in the bridge which depends on the concentration of the sample gas.

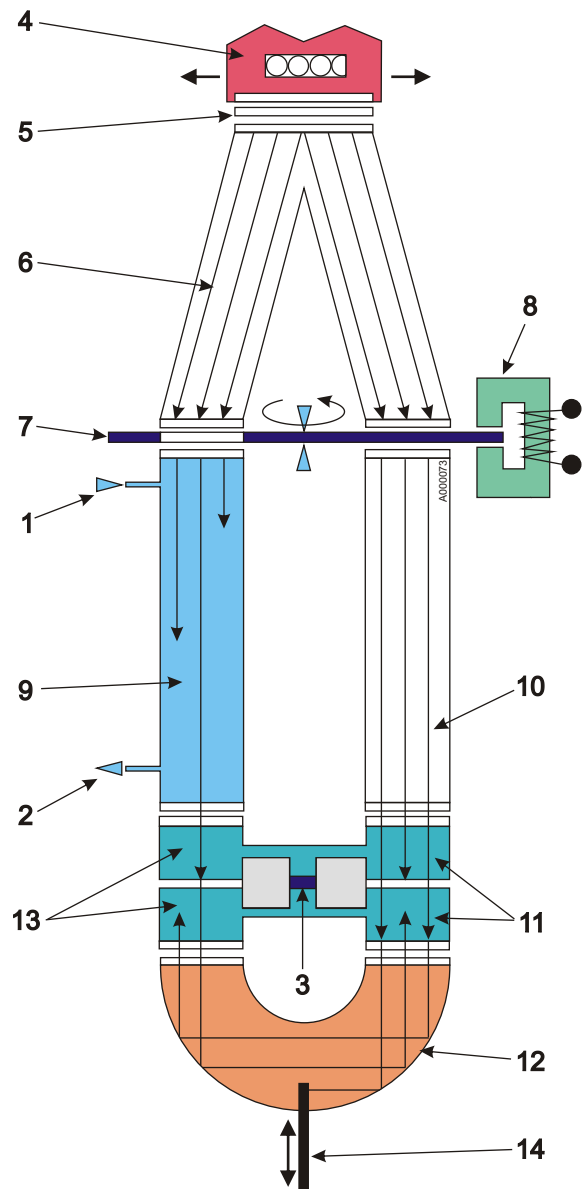

- 1 sample gas inlet
- 2 sample gas outlet
- 3 microflow sensor
- 4 IR source
- 5 optical filter
- 6 beam splitter (gas filter)
- 7 chopper
- 8 chopper drive
- 9 sample cell
- 10 reference cell
- 11 detector chamber, right
- 12 optical coupler
- 13 detector chamber, left
- 14 slider, adjustable

Technical Data

Measurement ranges	4, manually and externally switchable; autoranging is also possible	Measurement response ²⁾	
Smallest possible measurement range	dependent on application CO: 0 to 10 vpm CO ₂ : 0 to 5 vpm	Noise	< ± 1% of smallest possible measurement range (see type plate)
Largest possible measuring range	dependent on application	Zero drift	< ± 1% of measurement range / week
Characteristic	linearised	Span drift	< ± 1% of measurement range / week
Linearity error	≤ 0.5% of full scale value	Repeatability	between 0,1% and 1% of respective meas. range depending on model
Control panel	LCD with LED backlighting and contrast control, softkeys, numeric keypad and function keys	Influencing variables ³⁾	
Display of measured value	5-digit, resolution dependent on selected range; the number of decimal places is selectable	Ambient temperature	< 1% of measurement range / 10 K
EMC (electromagnetic compatibility)	according to NAMUR requirements NE21 (05/93); CE designation EN 50081 part 1, EN 50082 part 2	Sample gas pressure	with pressure compensation switched on: < 0.15% of setpoint with 1% change in pressure
Position of use	front panel vertical	Sample gas flow	negligible
Dimensions	19", 4 HU = 177 x 483 x 476 mm	Power supply	< 0.1% of output signal span at rated voltage ± 10%
Weight	approx. 15 kg (single channel analyser) approx. 21 kg (dual channel analyser)	Electric inputs and outputs per channel	
Power supply		Analog output	0 / 2 / 4 to 20 mA floating load ≤ 750 Ω
Power connection	AC 100 to 120 V, 48 to 63 Hz (rated range: 90 V to 132 V) AC 200 to 240 V, 48 to 63 Hz (rated range: 180 V to 264 V)	Relay outputs	6, with changeover contacts, freely settable e.g. for range identification: AC/DC 24 V / 1A floating, non sparring
Power consumption	approx. 40 VA (single channel analyser) approx. 75 VA (dual channel analyser)	Analog inputs	2, designed for 0/2/4 to 20 mA for external pressure sensor and correction of influence of residual gas (correction of cross-interference)
Gas inlet conditions		Binary inputs	6, designed for 24 V, floating, freely settable e.g. for range selection
Sample gas Pressure	0.5 to 1.5 bar absolute	Serial interface	RS 485
Flow	20 to 90 l/h (0.3 to 1.5 l/min.)	Options	additional electronics with 8 binary inputs and 8 binary outputs, e.g. for triggering the automatic calibration electronics for profibus PA (available soon)
Temperature	0 to 50 °C	Ambient conditions	
Humidity	< 90% RH ¹⁾ or depending on application	Permissible ambient temperature	-30 to +70 °C during storage and transport +5 to +45 °C during operation
Time response		Permissible humidity	< 90% RH ¹⁾ as annual average during storage and transport ⁴⁾
Warm-up time	at room temperature: < 30 min;	Protection class	IP 20 (NEMA 2; EN 60529)
Response Time (T ₉₀ time)	user adjustable		
Damping	0 to 100 s adjustable (electric time constant)		
Dead time	approx. 0,5 to 5 s depending on model (purging time of gas path in analyser at 1 l/min.)		
Time for internal signal processing	< 1 s		
Pressure correction range			
Pressure sensor (internal or external)	700 to 1200 mbar absolute		

¹⁾ RH: relative humidity

²⁾ Maximum accuracy achieved after 2 hours

³⁾ Referred to 1 bar sample gas pressure, 0,5 l/min. sample gas flow and 25 °C ambient temperature

⁴⁾ Keep always above dew point